

Thank you for your purchase of a Microlog Technologies product.

The Microlog DMM-1 Battery/DC System Monitor is a digital instrument that precisely measures the state of batteries in boats and recreational vehicles (RV'S). Precision digital monitoring allows a more accurate battery status reading and therefore delivers the necessary data to manage electrical resources more efficiently. In challenging circumstances, such as at sea, this information may be crucial in making important decisions. The system is designed to monitor the voltage status of up to two batteries or battery banks, current flow of charging devices and separate equipment current consumption. It does not count Amp-Hours. An integrated alarm system is also included, sending a warning signal, should the voltage of any battery fall under 11.8 volts or exceed 15.1 volts, while charging. The Microlog DMM-1 system is made with the finest components and materials in order to optimize its reliability and performance.

A typical boat 12 Volt system include two batteries: one battery (battery bank or house bank) is usually assigned to feed electrical appliances (fridge, lighting etc.), the second battery is dedicated to start the engine (See typical installation in Figure 1). Some boats can have two house banks and two engine batteries. RV's may include one engine battery, one generator battery and two house banks. The DMM-1, in those situations, should be assigned to monitor the two house banks, as those ones will likely be subject to deep discharge. Each DMM-1 Battery input can measure Voltage levels of one individual battery or one bank of several batteries. Total charging or discharging current to be measured, is passed through the "Shunts".

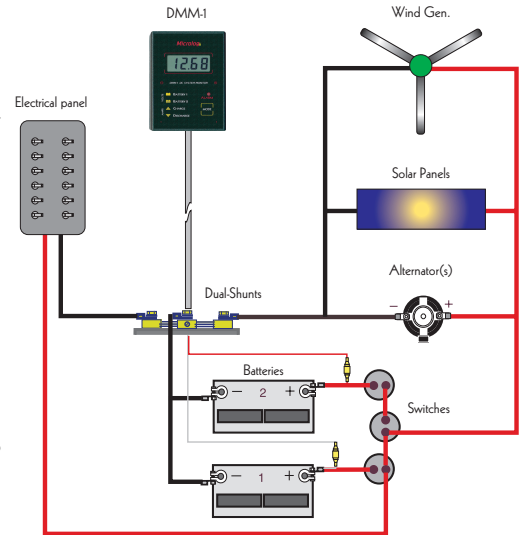

Figure 1: Typical installation

Measuring Voltage:

Measuring Specific gravity of the battery electrolyte (acid+water) in each cell of a lead-acid battery with caps will tell the level of charge but it can be messy and is not an easy task. Voltage indication is also a prime way to learn the status of charge of your batteries. This voltage also corresponds to the level of specific gravity related to any given level of charge. A Lead-Acid Battery voltage level of 11.7 Volts at rest (no load or charging device), indicates a completely discharged battery, while a voltage level of 12.60 Volts (12.95 Volts/Gel-cell), without any charging device connected, indicate a full charged battery (at room temperature). Any battery that discharges often below 11.6 volts (50%, under load) will eventually shorten its service life. The typical status of charge of your batteries is shown in the following table and chart, readings will vary with type and capacity of your batteries:

Percent of charge	Battery Voltage at rest (no load or charging device)			Lead-acid Battery Voltage (under load, C/10 no charging device)	Specific Gravity
	Lead-acid	Gel-Cell	AGM		
100%	12.60 V	12.95 V	12.80 V	12.50 V	1.255-1.275
75%	12.42 V	12.65 V	12.60 V	12.30 V	1.215-1.235
50%	12.18 V	12.35 V	12.30 V	12.05 V	1.200-1.180
25%	12.00 V	12.00 V	12.00 V	11.60 V	1.165-1.155
0%	11.70 V	11.80V	11.80 V	11.00V	1.130-1.110

Typical Battery Voltage vs % of charge chart at 77°F (25°C.) (according to a major battery manufacturer)

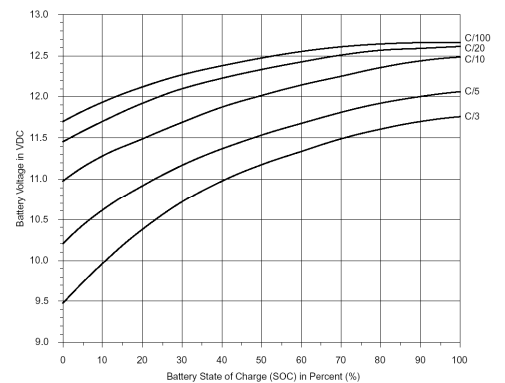

SHUNTS (TOP VIEW)

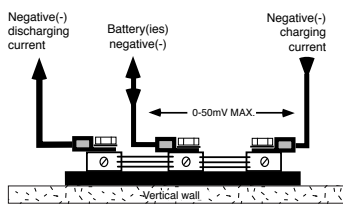

Figure 2: Typical current flow in shunts

Measuring Current:

The Microlog DMM-1 has 2 separate current measurement circuits, one circuit for charge current and one for discharge current. Our instrument does not measure AMP-HOUR type of readings. It rather measure the actual current produced by the charging equipment and, separately, the current consumed by electrical devices on board. Current measurement is determined by creating a very small voltage drop (0 to .050 Volts maximum) in a dual shunt (included in the accessory kit) connected to the negative side of charging and/or discharging devices. Your DMM-1 instrument is measuring this small voltage drop on the shunts and convert this measurement to display a current reading. Measuring these slight variations in voltage is critical in order to achieve an accurate reading. All measured current MUST pass through the shunts. Current flow is indicated by a + or - sign.

The different Battery Charging Stages can be monitored with your DMM-1:

- 1-The BULK stage of charging is the first stage and the AMP level will be equal to the maximum output delivered by your charging equipment or between 25-40% of your Amp-Hour battery capacity (also limited by the maximum output of the charging equipment). A typical Alternator will deliver 38-60 Amps (gradually decreasing) to a 150 Amp-Hour (AH) battery. You will get 75% of your battery charge with this stage. The voltage will be higher than the preceding Typical Battery voltage chart.
- 2-The second stage called Absorption stage will provide the remaining 25% of charge to the battery (ies) where they will be considered fully charged with a remaining current of 2-4% of the AH battery capacity (3-6 Amps, with a 150 Amp-Hour (AH) battery, on the DMM-1 charge mode) with a voltage of 14.4 Volts (14.2 for gels). This stage is slower as the current is lower and some people will stop charging stage before the 2-4% of the AH battery capacity point has been reached.
- 3-The Float Phase stage will maintain the battery charge after the full charge point has been reached.
- 4-The Equalization stage is optional on some battery chargers and allows you to de-sulphatize your batteries with a higher voltage.

The alternator, or other charging devices, will raise the battery (ies) voltage to 14.4 Volts. This voltage information combined with the level of current supplied will tell you when you have reached the full charge status.

INSTALLATION

The DMM-1 must be located inside the boat or vehicle in order to protect it from weather damage. Choose a location, which is accessible, close to the electrical panel, or close to navigational equipment. Be sure to have sufficient space behind the panel to allow wire leads to be connected easily. Remember to leave at least 0.5 inches (1.25cm) clearance above the unit in order to slide it into position on the small mounting plate.

1-Place the DMM-1 and the drilling template in position on the wall or control panel on which it is to be installed.

2-Remove the DMM-1 while holding the drilling template in position on the wall or panel on which the unit will be mounted. Tape this template in position.

3-Drill 1/16-inch (1,5 mm) holes in the indicated positions on the template, then remove the template.

4-Use the four screws supplied with the unit, to affix the mounting plate in position on the wall or panel.

DO NOT TIGHTEN SCREWS TOO MUCH, AS THIS WILL PREVENT THE UNIT FROM SLIDING ON AND OFF THE MOUNTING PLATE.

5-Drill a 1/4 inches (6 mm) hole, using the mounting plate as a guide, to allow wiring access to the unit.

6-Run the DMM-1 wires through the 1/4-inch (6 mm) hole in the mounting plate, snap the DMM-1 over the mounting plate then slide it down to final position.

7-Run the wiring from the battery compartment towards the DMM-1 unit. (Do not connect batteries or shunts now).

8-Connect the DMM-1 wires to the screw terminal strip first, then connects the wires coming from the battery compartment.

IMPORTANT WARNING: The DMM-1 internal circuit is protected from short circuits by an automatic internal breaker, but the wiring connected to the battery terminal (s) is not protected unless a fuse is installed. YOU MUST install 0.5 Amp. (max.) fuses on the monitoring + (white and red) leads connected close to the batteries positives (+) terminals for added short and FIRE PROTECTION.

A-Installing the DMM-1 for voltage measurement only (without shunts):

Figure 3 illustrates the proper wiring installation of the DMM-1 unit (without shunts) for voltage measurement and alarms only. The following steps will guide you through the procedures. Your DMM-1 is calibrated with a length of 25 feet of #22 special cable (included in our accessory kits) and we suggest using the full length of cable for maximum accuracy.

1-Link all the negative battery terminals together (may be already done), with heavy gauge wire, to create a common negative point (-) (see figure 3).

2-Connect the BLACK, BROWN, GREEN and BLUE wires together to the common negative point (-) (at the instrument terminal strips if you do not use our special cable) and then to the long cable to the batteries. Note: the separate ground wire (black) and sensor negative wire (brown) are designed to increase the instrument's reliability and accuracy.

3-Connect the RED wire from the DMM-1 unit to the #2 battery through the fuse.

4-Connect the heavier gauge WHITE wire from the DMM-1 unit to the positive (+) battery terminal of the #1 battery through the fuse. This wire is also used to feed power to the DMM-1 instrument.

Screw	Connect to	Wire Color
#1	Negative Batteries	Black
#2	Negative Batteries	Brown
#3	Negative Batteries	Blue
#4	Negative Batteries	Green
#5	+12V/Bat.#2	Red
#6	+12V/Bat.#1	White

Should you wish to monitor the status of only one particular battery, connect the WHITE and RED leads to the positive terminal of that battery to avoid false alarms.

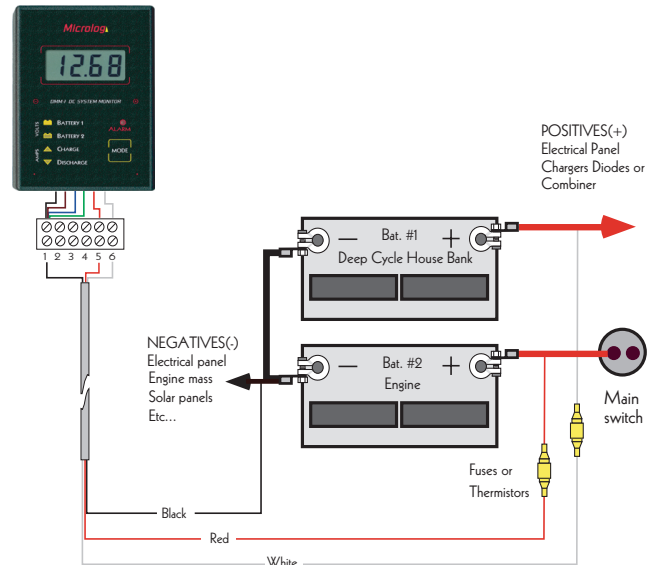

Figure 3: Installation without shunts

B-Installing the DMM-1 with dual-shunts:

IMPORTANT WARNING: Some boat and most RV's alternators have their NEGATIVE output connected to the alternator casing and engine mass instead of having a separate negative post. Engine starters are also connected the same way. If you connect the engine negative mass wire to the charge shunt and then to the starting battery, this could lead to excessive current (over 200Amp.) through the shunt. When you start big engines (more than 4 cylinders) for more than a few seconds, you may possibly damage the shunt and prevent the engine from starting. It is therefore very important, in this case, to have an Alternator NEGATIVE output isolated from engine mass or only measure the House bank(s) charge and discharge current (as installed according to fig. 6) so high starting surge current will not pass through the shunts. Under NO circumstances the House Banks will then be used to start big engines.

Figure 4, 5, and 6 illustrate the correct installation of the DMM-1 unit with Dual-Shunts. The following steps will guide you through the proper procedures.

Figure 5 show the best installation diagram if you have Alternator (s) Negative (s) (-) Output(s) ISOLATED from the Engine (s) Mass.

If it is not possible to have a separate Negative (-) Output (s) from the alternator (s), you can use the Figure 5 Installation for small Engines with 4 cylinders and less, only, where you have Alternator Negative (-) Output connected to the Engine Mass. You install as in following steps except you will monitor alternator output through the shunt, installed inline with the Black Engine Mass Cable.

Figure 6 show the installation diagram for Single or Dual Engines with more than 4 cylinders in Powerboats and RV's, where you have Alternator(s) Negative(s) (-) Output(s) connected to the Engine(s) Mass. and you cannot have them isolated. You install as in following steps except you will monitor alternator output and charging equipment to the Deep cycle Batteries or House banks only.

The following steps will guide you through the proper procedures:

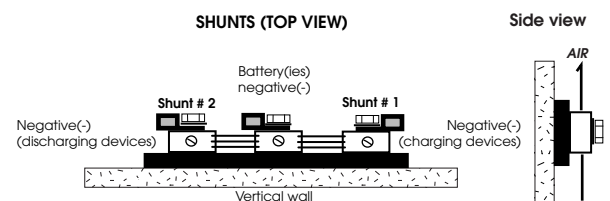

Figure 4: Dual Shunts Physical installation

Your DMM-1 has been calibrated with 25 feet (7.5 meter) of our special cable. We suggest using the full length of cable for maximum accuracy.

1- The Dual-Shunt MUST be mounted horizontally on a vertical wall to ensure the proper ventilation and cooling of the small shunt plates (see figure 4).

2- Your Dual-Shunt has a center mount with Bolt. This center post will act as a Common Negative Point (-) (see figure 4).

Connect the negative (-) terminal(s) of the battery(ies) to be monitored for current flow, to the Common Negative Point. Use heavy gauge wiring to ensure good conductivity and provide heat dissipation. **DO NOT OVER-TIGHTEN BOLTS ON BRASS SHUNTS.**

3- All monitored 12 volt charging equipment NEGATIVE (-) wires should now be connected to the charging shunt bolt. You can choose LEFT or RIGHT side for charge or discharge current to best fit your

Screw	Connect to	Wire Color
#1	Dual shunt center (- negative)	Black
#2	Dual shunt center(- negative)	Brown
#3	Discharge shunt (- negative)	Blue
#4	Charge shunt (- negative)	Green
#5	+12V/Bat.#2(+ #3)	Red
#6	+12V/Bat.#1	White

Table 3: Wiring installation

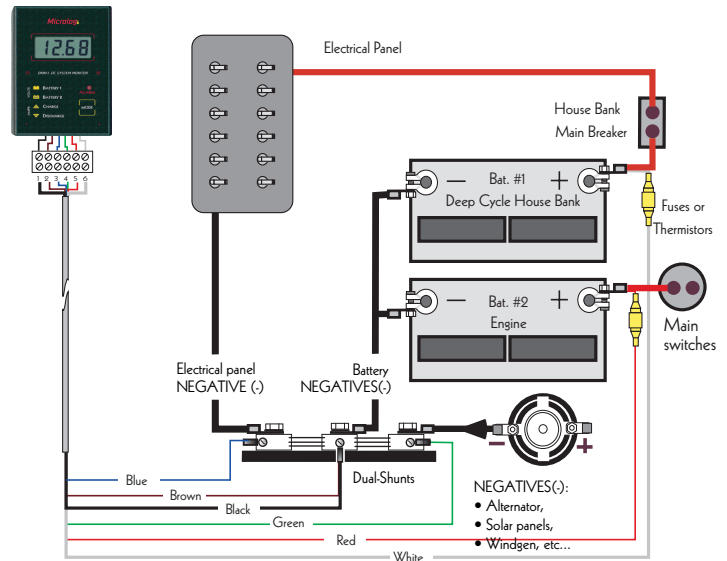

Figure 5: Installation for SMALL (4 cylinders and less) engines ONLY

existing wiring installation.

4- The electrical distribution panel NEGATIVE (-), winlass and inverter should be connected to the discharging shunt bolt.

5- Connect all small wires at the instrument terminal strip behind the DMM-1 and then to the install th long special cable to the batteries compartment. See Table 3 for wiring installation.

6- Connect the BLACK and BROWN wires from the DMM-1 unit cable to the small screw on the center mount on dual-shunt.

7- Connect the BLUE wire from the DMM-1 unit to the small screw on the discharging shunt mount (LEFT), which is linked to the discharging equipment or electrical panel NEGATIVE (-).

8- Connect the GREEN wire from the DMM-1 unit to the small screw on the charging shunt mount (RIGHT), which is linked to the charging equipment NEGATIVE (-).

9- Connect the RED wire from the DMM-1 unit to the #2 battery (or battery bank) through the Fuse. **We included 0.5A Fuses for battery wiring short protection.**

10- Connect the WHITE wire from the DMM-1 unit to the positive (+) battery terminal of the #1 battery through the Fuse. This wire is also used to feed power to the DMM-1 instrument.

Note: If you are only using only one battery, combine the DMM-1's WHITE and RED wires together to the positive (+) battery terminal through the Fuse.

You can install a small toggle switch for Bat. #2 and Bat. #3 voltage monitoring on input # 2 of the DMM-1.

OPERATION

- If the DMM-1 display is blank, press on the MODE button to activate the unit.

The Operation Modes:

- There are four monitoring modes: Battery 1, Battery 2, Charge and Discharge.

Use the MODE button to toggle through these choices. An indicator light will appear on the selected mode:

- Battery 1: monitors the voltage of the first battery.
- Battery 2: monitors the voltage of the second battery.

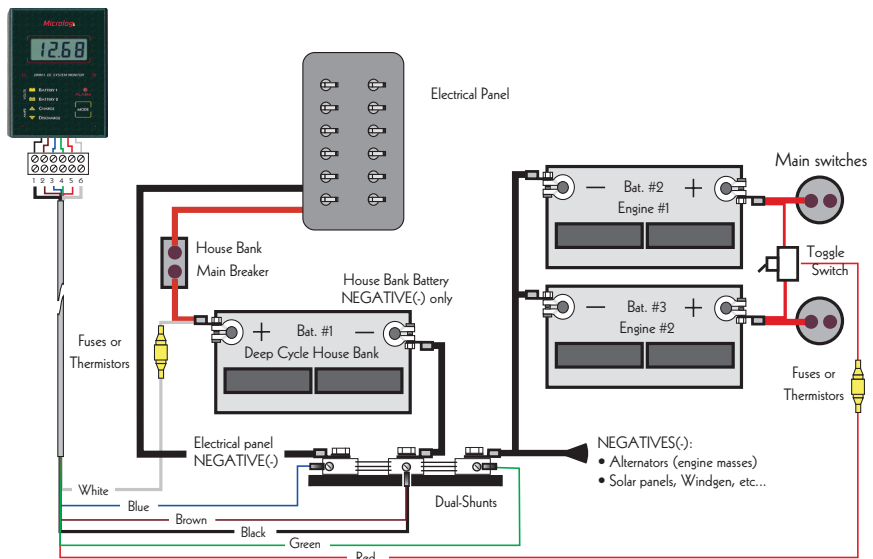

Figure 6: Dual or Single big engine(Power Boat or RV) DMM-1 Shunts and wiring installation where alternator(s) negative(s) is connected to the engine(s) mass(es)

- Charge: monitors the current in AMPERES (AMPS) of the charging circuit.
- Discharge: monitors the load current of appliances and equipment running on the batteries.
- Off: a fifth mode position, the OFF mode, deselects the above modes and alarms are disabled.

This unit features a high and low voltage alarm which once triggered sends a visual (LED) signal as well as an audio signal. When an alarm condition occurs, each battery bank can be verified for its respective condition. The alarm is triggered when any battery bank is under 11.8 Volts or over 15.1 Volts. This IS NOT related to the chosen mode. You must put the DMM-1 in OFF MODE to deactivate the Beeper and correct the situation.

TROUBLESHOOTING

The DMM-1 displays inaccurate voltage readings:

- Verify that BOTH BLACK and BROWN leads from the DMM-1 are connected to the small screw located on the center dual-shunt mount (or the battery common negative point on batteries or terminal strip if you are NOT using shunts).
- Your DMM-1 is calibrated with 25 feet of our special cable and we suggest using full length of cable and our Dual-Shunt for maximum accuracy.
- Your VHF or SSB can induce your DMM-1 through the wiring network and increase the voltage reading slightly when transmitting.
- Some battery chargers and AC power lines or connected equipment can induce noise-affecting readings of DMM-1.

The DMM-1 displays inaccurate current readings:

Problems can arise when monitoring current as the DMM-1 measure very small voltage drop in shunts.

- Verify shunt installation for loose wiring and ensure that the all heavy wire gauge is well connected and bolted to the shunts.
- Verify that the black, blue, green and brown leads from the DMM-1 are well connected to shunts and at the DMM-1 instrument.
- Verify that the BLACK and BROWN leads from the DMM-1 are not connected together at DMM-1 term. block or contacting any other leads.
- Your DMM-1 is calibrated with 25 feet of our special cable and we suggest using full length of cable and our Dual-Shunt for maximum accuracy.
- You may have equipment (s) negative (-) (s) which are not connected to the Distribution Panel discharge shunt but rather on the Engine mass, boat keel or hull or RV frame instead. All the measured current must pass through the Charge and Discharge Shunts in line with the Negative Battery Wiring. The slightest leak between the alternator, chargers NEGATIVES or engine mass, connected to the charge shunt, and any discharging devices can cause errors or falsify readings of the separate charging or discharging circuits. It is therefore very important to have wiring connected as in Figure 5 or 6.
- The VHF radio antenna that is installed atop the mast of sailboats may also cause current leaks. The coaxial cable brings the negative to the antenna, then to the mast, then to the lightning grounding path including the engine and the un-insulated alternator case and finally to the charge shunt to cause a reading error. All ground leak problems are critical, especially on metal boats and even more on aluminum ones.

The alarm is active

- Check both voltages readings as 1 or 2 batteries voltages are below or over the normal values OR an input fuse is blown.
- Check small wires for connections to the terminal block behind the DMM-1.
- If you are only using only one battery (or battery bank), combine the DMM-1's White and red leads together to the positive (+) battery terminal.

LIMITED WARRANTY

Microlog technologies Inc. warrants to the original purchaser, only for 24 months from the date of purchase, that the DMM-1 instrument will be in good working order when properly installed and operated as described in this Manual. If your DMM-1 fails to perform or becomes defective under normal use and service, you must first obtain a Return Merchandise Authorization (RMA) and pay shipping to our facility for repair. Collect or shipment without RMA will not be accepted. We will pay shipping for returning the instrument anywhere in North America if it is under warranty. Our Warranty DOES NOT cover shunts, wiring and accessories.

AS WE HAVE ABSOLUTELY NO CONTROL ON THE WAY YOU INSTALL YOUR ELECTRICAL EQUIPMENT, ALL WARRANTIES ARE STRICTLY LIMITED TO THE DMM-1 INSTRUMENT FUNCTIONALITY AND NO OTHER EXPRESSED OR IMPLIED WARRANTY IS APPLICABLE. THE FOREGOING WARRANTY IS IN LIEU OF ALL OTHER WARRANTIES, INCLUDING THE WARRANTIES OF FITNESS FOR A PARTICULAR PURPOSE AND MERCHANT-ABILITY, EXPRESS OR IMPLIED, AND OF ALL OBLIGATIONS OR LIABILITIES ON THE PART OF MICROLOG TECHNOLOGIES INC. FOR DAMAGES, INCLUDING, BUT NOT LIMITED TO LOSS OF TIME, INCONVENIENCE, COMMERCIAL LOSS OR CONSEQUENTIAL DAMAGES, WHICH MAY ARISE OUT OF OR IN CONNECTION WITH THE USE OR PERFORMANCE OF THE INSTRUMENT.

Some states do not allow the exclusion or limitation of incidental or consequential damages, limitations on how long an implied warranty lasts, so if the law of that state applies, the above limitation or exclusion may not apply to you. This warranty gives you specific legal rights and you may also have others, which vary, from state to state.

SPECIFICATIONS

DMM-1 Specifications:

Voltage measurement range:	8.0 -17.0 V
Resolution (volts):	0.01 V
Measurement precision:	± 0.03 V (20°C)
Low voltage level alarm trigger:	11.8 V ± 0.1
High voltage level alarm trigger:	15.1 V ± 0.1
Current measurement range:	0 - 200 A
Resolution (amperes):	0.1 A
Measurement precision:	0.2 A (20°C)
Operating current requirements:	2.0mA (off) - 18.0mA (on)
Operating temperature range:	0 - 40°C (32°F to 104°F)
Storage temperature range:	-30° to + 60°C (-20°F to 140°F)
Size:	4.3 " X 3.3 " X 0.9 "
	11.1 cm X 8.2cm X 2.3cm

v.: 10-06

Sogeman-Microlog Technologies Inc.
 2720 Cr. Alma, Laval, Qc, Canada, H7E 1K4
 • Tel. : 450.664.2664
 • email : info@microlog-tech.com
 • Web: www.microlog-tech.com